

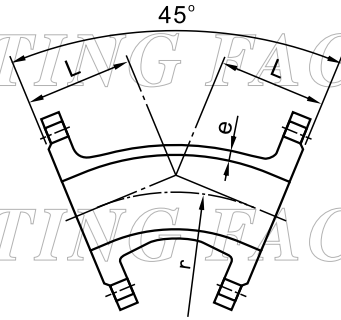

Double Flanged 45° Bends



Unit : mm

Nominal size DN	e	L	r approx.	Mass with flange (Kg)		
				PN 10	PN 16	PN 25
80	7.0	130	190	9.3	9.3	9.3
100	7.2	140	200	11.3	11.3	12.3
150	7.8	160	230	18.5	18.5	20.5
200	8.4	180	265	27.4	27.0	31.2
250	9.0	350	660	54.8	54.0	61.8
300	9.6	400	765	77.8	77.0	88.2
350	10.2	300	505	76.8	83.0	99.6
400	10.8	325	550	95.8	107.0	129.6
450	11.4	350	595	116.2	132.0	153.8
500	12.0	375	645	144.6	175.0	198.4
600	13.2	425	735	216.4	266.0	297.8
700	14.4	480	875	301.4	335.0	401.0
800	15.6	530	1000	405.6	444.0	542.4
900	16.8	580	1100	528.2	567.0	696.8
1000	18.0	630	1200	674.0	751.0	912.6
1100	19.2	695	1300	861.0	931.0	1076.8
1200	20.4	750	1400	1058.4	1178.0	1386.0
1400	22.8	775	1595	1462.8	1524.0	1903.4
1600	25.2	845	1800	2069.0	2119.0	2627.2